

# Cassina

## 675 MARALUNGA 40 MAXI

Year of design **1973**

Forty-five years after the launch of the original, and following on from the Maralunga 40 and its variant, the 40S with removable fabric covers, the Maralunga sofa takes the stage once more, its proportions updated, and its look restyled, becoming even more elegant and comfortable than before. Maralunga 40 Maxi is a contemporary take on this legendary best-seller by Cassina, which holds the technological patent for the device – a bicycle chain – that adjusts the angle of the back-rest. Supplied with the refined edge-stitching finish as standard, the Maralunga 40 Maxi armchair debuts a new size for its type: 122 cm. Meanwhile, the two-seater sofa comes in at 214 cm, with the three-seater measuring 310 cm. The depth has increased to 105 cm, to make for a more inviting and comfortable sitting position; all the models can be fitted with a feather-filled seat cushion in a new size to enhance ergonomic correctness.

### Gallery



### Dimensions

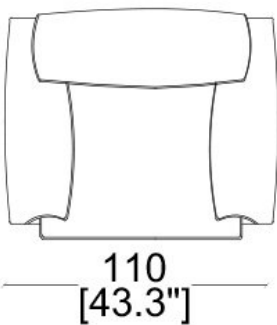
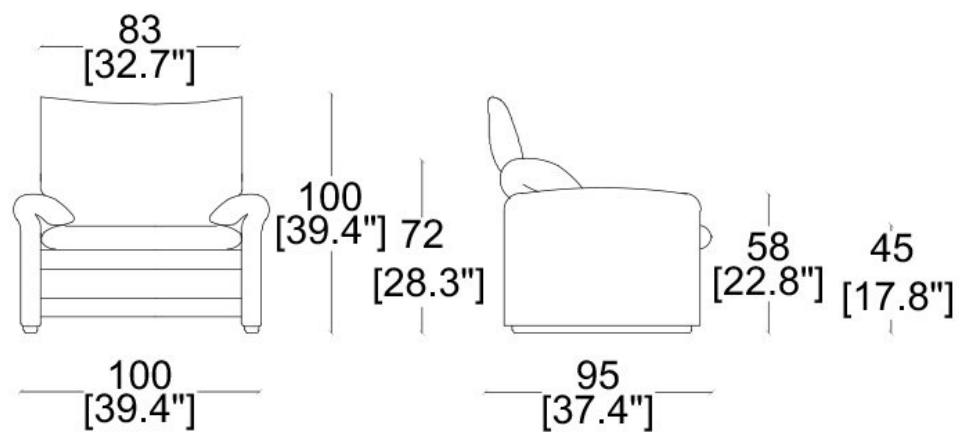
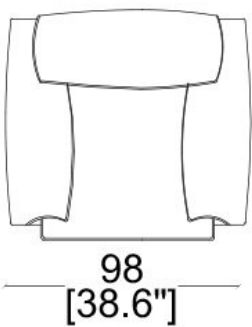
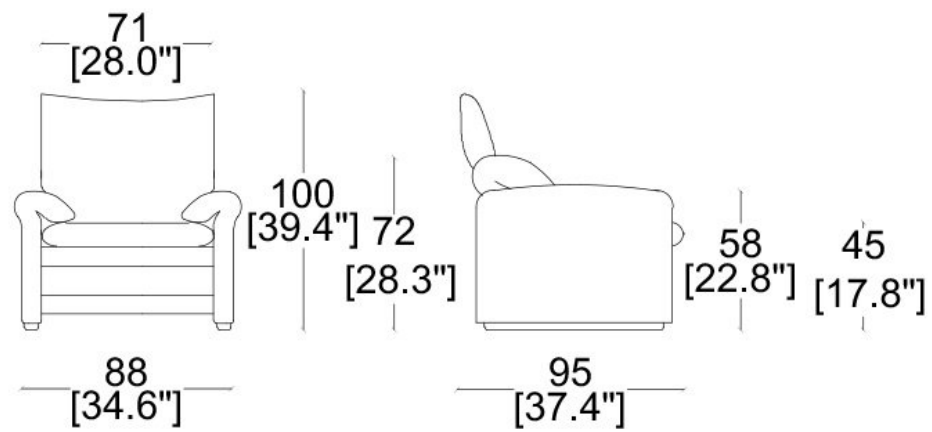

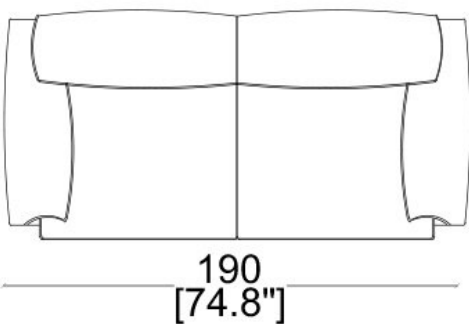
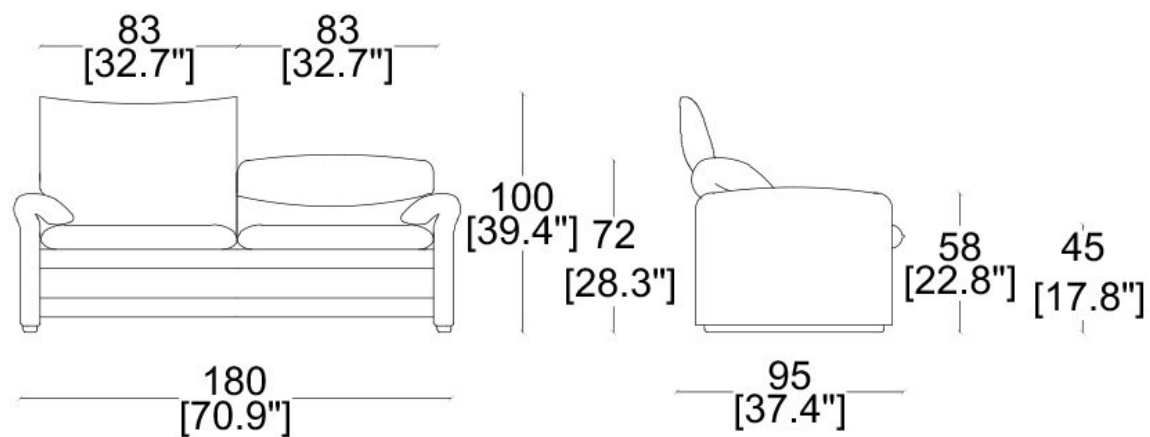
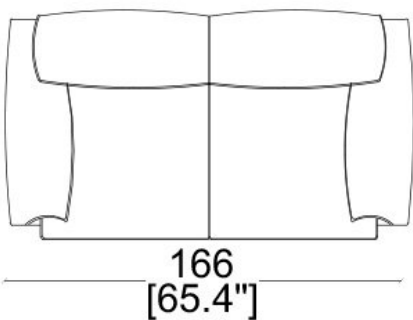
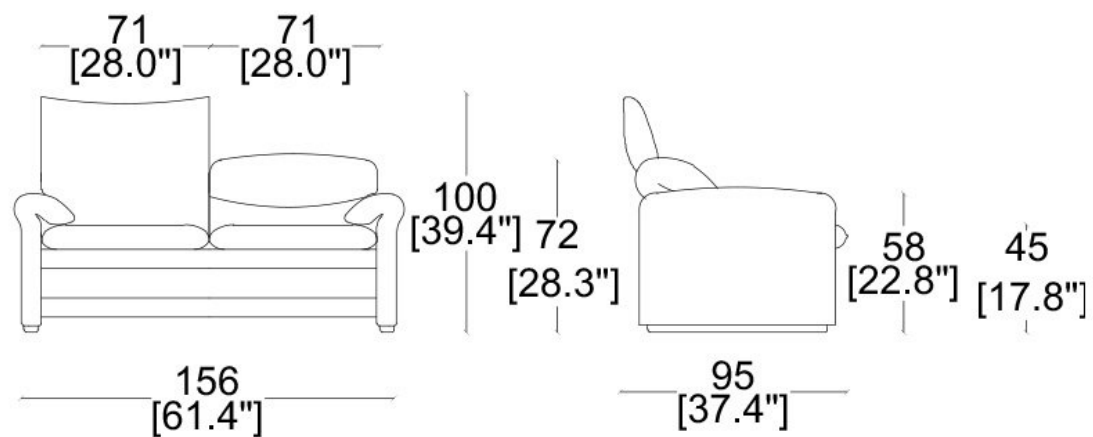

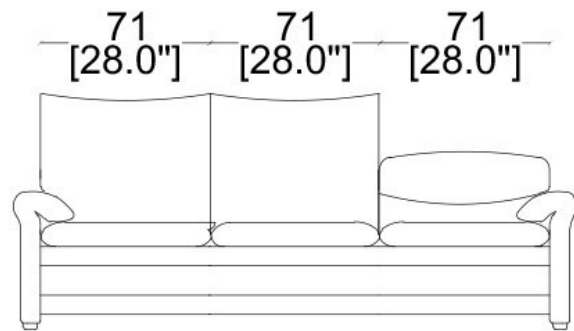

100 [39.4"] 72 [28.3"]

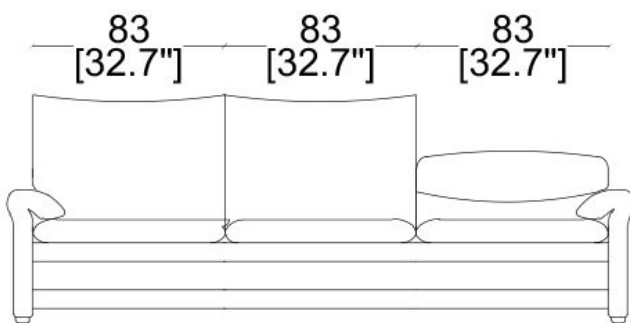
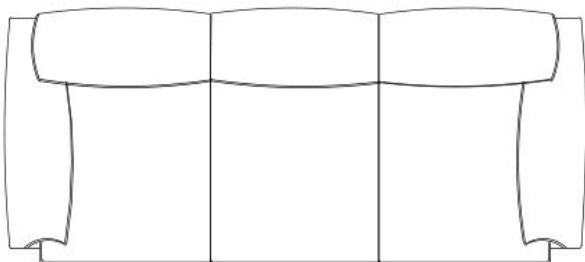
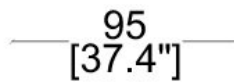
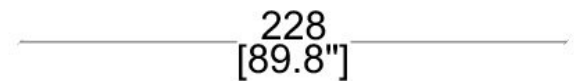
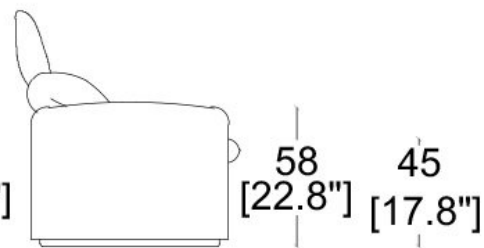

100 [39.4"] 72 [28.3"]

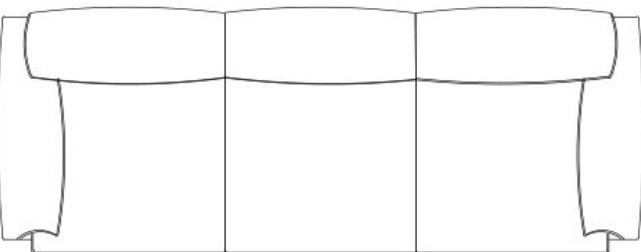
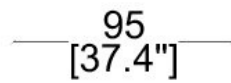
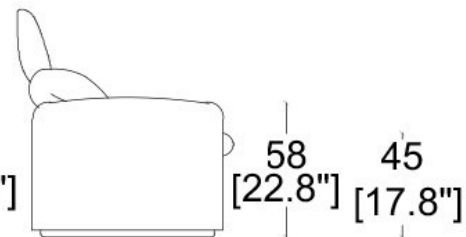

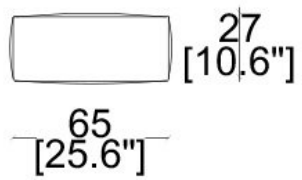
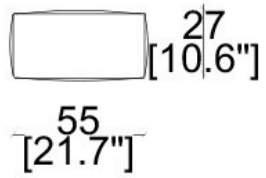
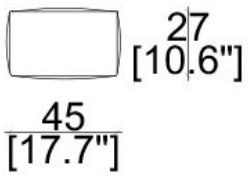
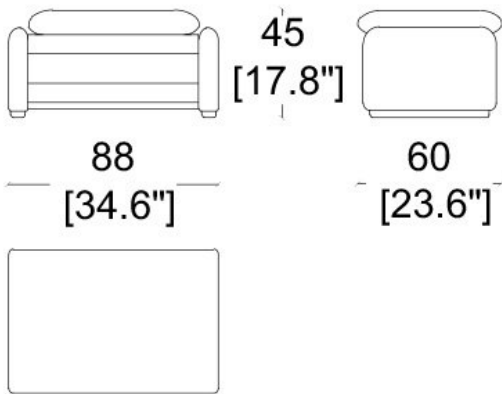

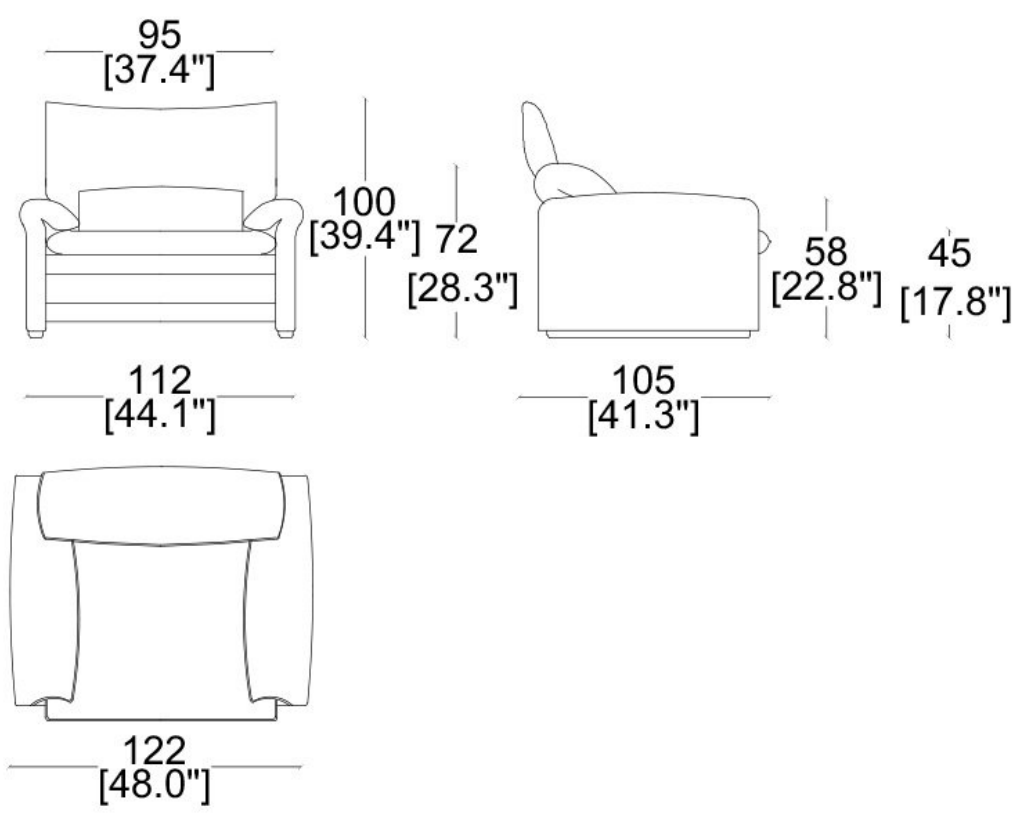
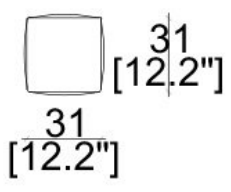

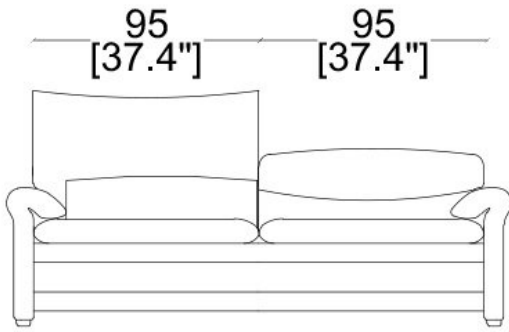

100 [39.4] 72 [28.3]

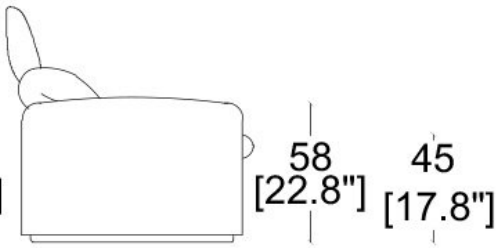

204 [80.3]

105 [41.3]

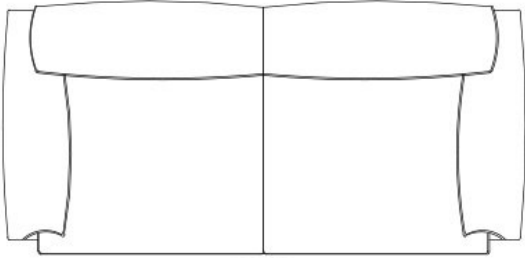

214 [84.3]

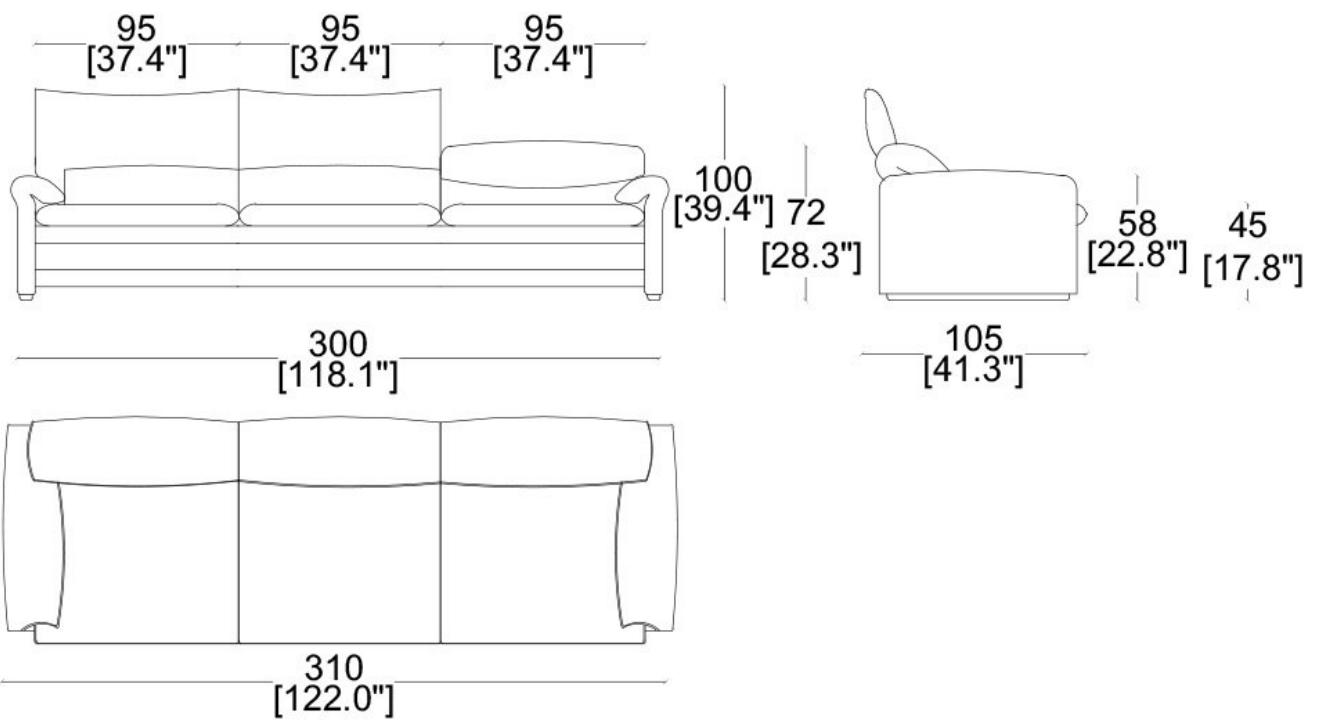



## Designer

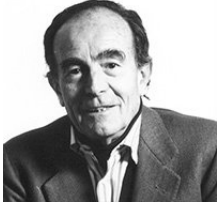

**Vico Magistretti**

In 1920 Magistretti was born in Milan, the city in which he graduated in architecture in 1945, and where his professional career has spun its story ever since, chiefly in the fields of architecture, town planning and industrial design. The first recognition of his work came in 1948, when he won the Gran Premio at the 8th Triennale. After that came almost forty years of activity with other prizes and awards in recognition of Magistretti's work in various sectors in different countries.

Giving lessons and lectures in various faculties of architecture and schools of design in Italy and abroad, from Milan to New York, from Paris to London, a city to which he is particularly devoted, he has been an "Honorary Fellow" of the Royal College of Art since 1983.

Furniture, lamps and other objects that he designed may be found all over the world and the most important design museums have given exhibitions in his honour and kept examples of his work in their permanent collections.

Magistretti's research has been continuous - into design, the culture of the project and innovative experimentation with materials and space solutions, not to mention shapes and functions far from the rigours of fashion that they have passed through during the years. He started designing for Cassina in 1960, and from that date on his signature is to be found on very many products. We recall in particular the Maralunga sofa of 1973 and the Nuvola Rossa (1977) bookcase, which are still indisputable international best-sellers and have provoked hordes of imitations which have not been able to echo even faintly the success of the originals.

<http://www.vicomagistretti.it>